

STREETSUN

Designer solar light with added value

Application

The STREETSUN designer solar light is a solar-powered LED lighting solution that can be used at any location where there is no mains power supply. Thanks to its timeless, prizewinning design, the STREETSUN is excellent for lighting modern urban space as well as protected monumental structures. The ingenious operating system guarantees flawless function for several nights even during the worst weather. According to DIN EN13201 the STREETSUN is superlative for the illumination classes S5 and S6; that is to say, for side streets with minimal traffic, squares, parking places etc.

Function

Due to its modular assembly concept, the STREETSUN can be set up and focused with its optional ground dowel within an hour. In order to adapt the light to different light emission situations, two LED head variants (square and road) are available. As a standard, the specially developed energy management feature calculates optimal LED activation, in order to dim the light during defined periods as required and thus guarantee an energy reserve up to 3 nights long. The additionally integrated time management feature allows customers to choose, at no extra charge, (ex works) between 3 settings, and by nightly dimming or switching off to extend the reserve up to 4 nights in length. The STREETSUN is standard delivered with a heatproof battery (up to 60 °C).

Options

In addition to the standard colours of white and anthracite, the STREETSUN can also be ordered in other RAL colours at an additional charge.

An added-value package combines a guarantee extended to 6 years with replacement battery and special anti-theft screw set.



Technical data

Photovoltaics	
Module	Monocrystalline silicium cells
Open circuit voltage Uoc	17.1V
max. voltage Umpp	14.1V
Short circuit current Isc	2,080.5mA
max. current Impp	1,690mA
max. output Pmpp	23.6W
Tolerance Pmpp	+ - 3%
Dimensions module	328mmx506mmx9mm
Level of effectiveness of solar cells (moulded)	17%
Weight	330g
Guarantee (the guarantee period commences on production date)	2 years with 100% product guarantee 5 year guarantee on 90% minimum output 10 year guarantee on 80% minimum output



light distribution STREETSUN placevariant

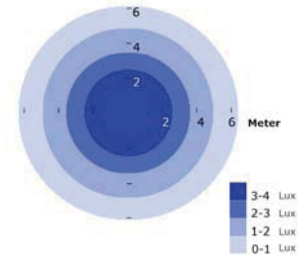

Battery	
Capacity	11.0Ah (NiMh)
Voltage	9.6V
Total output	6,500Ah
Battery life	approx. 5 - 6 years
Operating temperature	-15 to +60 °C
Miscellaneous	Battery also charges on cloudy days

light distribution STREETSUN wayvariant

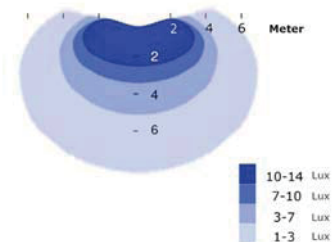

Illuminant	
Quantity LED	12
Output LED max.	12W
Luminous flux	typ. 420lm; max. 450lm; min. 300lm
Colour temperature	5,600K to 6,500K
LED life	> 50,000h
Light duration	to 15h per night, reserve 3 to 4 night lengths
Annual light duration	approx. 4,200h
State-of-the-art LED	Insect-neutral light

Energy and time management:

	Function	Light output	Time
1.	Dimming	50%	24:00-5:00
2.	Switching off	0%	24:00-5:00
3.	Continuous illumination* (with energy management)	100%	Shines all night

*We recommend the continuous illumination of the STREETSUN only in countries where an extreme amount of sun shines in.

Dimensions	
Total height from ground level	4.0m
Light point level from ground level	3.2m
Total mast length	3.6m
Length of mast installed in ground	0.6m
Materials	Mast aluminium, head PE weatherproof,

STRAATVERLICHTING

	long-term stable
Protection type	IP65
Guarantee/warranty	2 years (incl. battery)

Dimensions and weight for transport

Light head in box - Dimensions - Weight	800mmx600mmx340mm 16kg
Mast in round box - Length - Diameter - Weight	3,700mm 150mm 7.5kg
Krinner screw foundation in box - Length - Diameter - Weight	1,100mm 150mm 7.5kg

Maintainance cycles

Recommended Battery replacement	after 6 years
Recommended LED replacement	after 12 years

Tool for assembly (included)

1 x Allen key	4mm
---------------	-----

Possibilities of installation in ground area

Pipe base KRINNER screw base	KSF G3 114mmx1000mm (leaving technical changes)
---------------------------------	--

Dimensions:

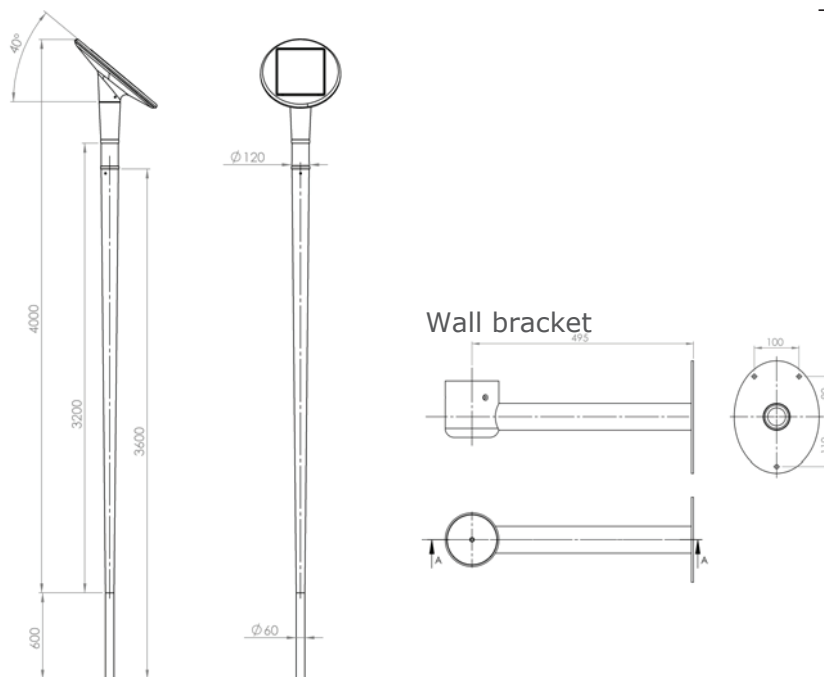

STREETSUN – Added value package

As additional service package we offer the following along with the STREETSUN solar street light:

- 6 year guarantee on the entire light
- Safety screw set for better theft protection, consisting of special screw driver (incl. pre-assembly at the factory)

- 1 replacement battery within the 6 year guarantee time (without on-site replacement)

- KRINNER ground screw „G3“ incl. 3x screws and counter-nuts M16 (without on-site replacement)

STREETSUN - for hot climate zones

For hot climate zones we recommend the STREETSUN either entirely in white or else anthracite with white light portion.

The light is standard delivered with heatproof battery that can tolerate up to 60°C.

STREETSUN wall bracket

- Material: ALU
- Powder-coated
- Optimal fastening height at 3.20 m from ground level to light point